



Bobcat®

One Tough Animal.

ELECTRIC FORKLIFTS

7-Series Plus, 1.6 to 3.5 ton capacity

🌐 EMEA



ONE TOUGH ANIMAL

OUR MISSION

We empower operators to accomplish more, while working in the toughest conditions and tightest situations. When our customers have the will, we provide the way.

INTRODUCTION

BOBCAT'S HISTORY

In 1958, Melroe Manufacturing Company introduced a compact front-end loader that evolved quickly into the M400, the world's first true skid steer loader. The company soon adopted what became the world-famous 'Bobcat' brand – and its success paved the way for the global compact equipment industry we know today.



YEARS OF EXPERIENCE

In 2021, Bobcat furthered its reach by acquiring Doosan Industrial Vehicle, increasing its capacity to provide customers with comprehensive business solutions. With Doosan's expertise in material handling and warehouse equipment dating back to its inaugural forklift in 1968, the company has established a global presence, with 400 dealers across 93 countries.



BOBCAT TODAY

Now, with a diversified portfolio that includes forklifts and warehouse equipment, Bobcat serves as a one-stop solution for intralogistics needs, from loading shipping containers to optimizing warehouse operations. Produced in its South Korean factory, Bobcat's material handling machines offer the precision and durability customers expect.



TOUGH, AGILE & SAFE

► READY TO GIVE YOUR BUSINESS A LIFT

Offering dual traction motors, power steering, and regenerative braking, our forklifts are designed to optimize performance. Plus, enjoy all-day comfort and dependability with enhanced cooling, water resistance, and reduced noise levels.

► OUTSTANDING PRODUCTIVITY
Boost productivity with exceptional driving performance, thanks to a tight turning radius, improved visibility, and a powerful motor system. **P. 6-7**



► ALL-DAY COMFORT
Enjoy the ergonomically designed adjustable steering and seats, complete with optional fingertip control for extra convenience. Plus, noise reduction ensures maximum operator comfort. **P. 8-9**



► SAFETY IN EVERY MOVE
This series comes equipped with a full suite of safety features, preventing potential hazards and providing a secure work environment. **P. 10-11**



► MAXIMUM UPTIME
The robust components guarantee durability and reliability, while easy access to all primary parts simplifies and streamlines maintenance. **P. 12-13**



OUTSTANDING PRODUCTIVITY



▶ EXCELLENT VISIBILITY

With the precisely designed overhead guard featuring angled roof bars and excellent visibility through the mast, you've got the best view of the task at hand.



▶ POWERFUL TRACTION AND PUMP MOTOR SYSTEM

Boost performance and productivity with a powerful pump motor system that delivers high traction and torque.



▶ EASY SIDE BATTERY REMOVAL

The battery changing system enables fast and easy battery exchange using Side Roll-In/Out or Side Lift In/Out methods, allowing for efficient multi-shift operations.



▶ OPTIMIZED STEERING ANGLE

Enjoy the freedom to work in tight spaces with our small turning radius, ensuring effortless maneuverability in and out.

COMFORT & CONTROLS



► PREMIUM ADJUSTABLE SEAT

Thanks to the adjustable suspension seat, our forklifts provide exceptional comfort even during the longest shifts. For added convenience, you can also equip the seat with a heating system to keep operators warm in colder environments.



► ADJUSTABLE COLUMN

The ergonomic steering wheel column offers stepless adjustment, enabling operators to position it precisely according to their needs.



► INTUITIVE INSTRUMENT PANEL

Adjust the truck's performance settings on the go with a simple touch of a button.



► CONVENIENCE TRAY

Experience maximum convenience with quick access to a large cup holder, USB port, 12V power outlet, clipboard holder, and more, all comfortably within reach.

► ANTI SLIP STEP & ENTRY BAR



The anti-slip step provides comfortable and safe mounting and dismounting of the vehicle for additional peace of mind.

► WELL-PLACED HANDLES



Thanks to the well-placed entry bar and handles, stepping in and out of the vehicle is as quick and comfortable as can be.

► EMERGENCY SWITCH



The emergency switch is easily accessible for quick activation in case of an emergency.

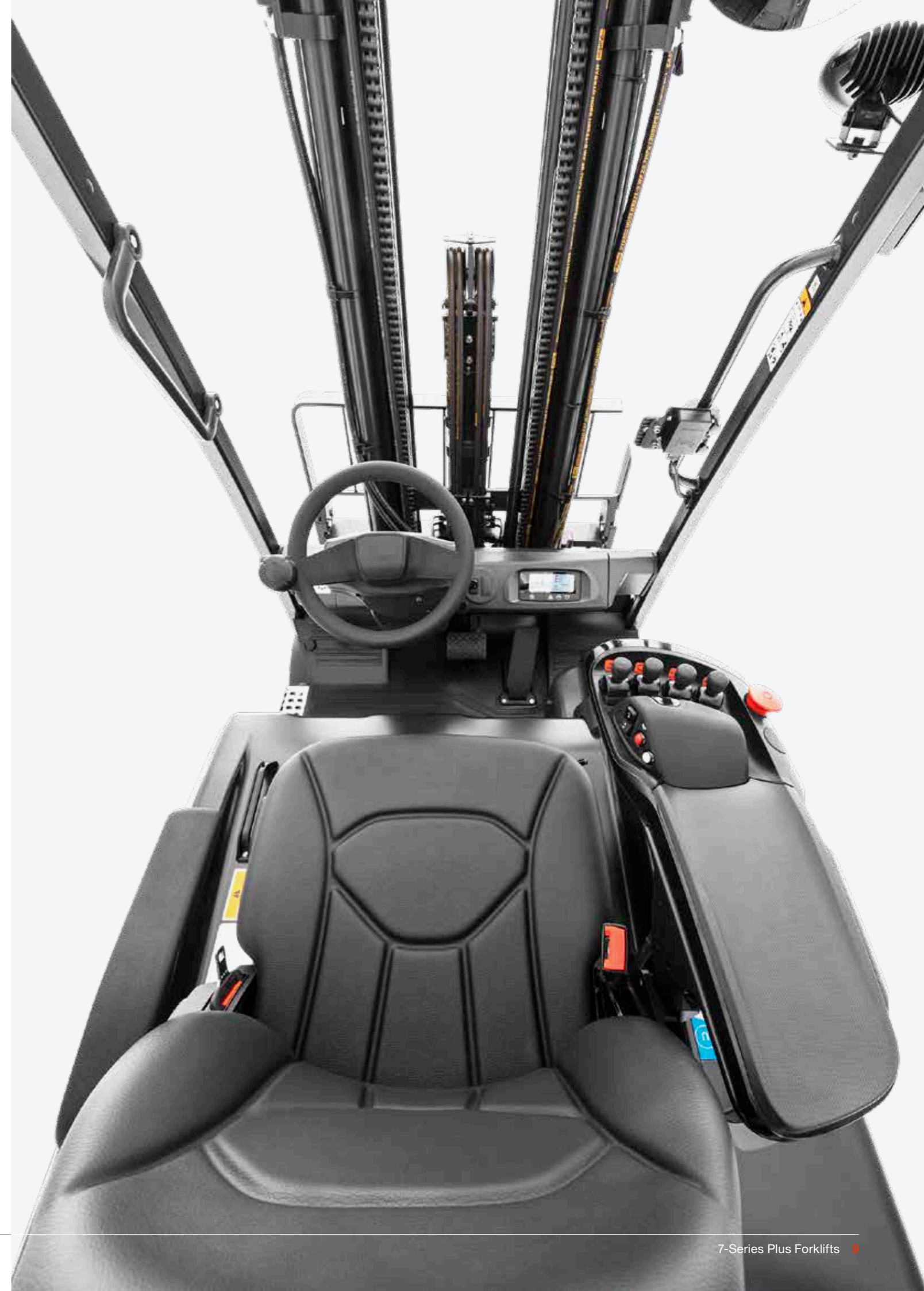

SAFETY IN EVERY MOVE

▶ ADVANCED PROTECTION FOR YOU AND YOUR OPERATION

Bobcat forklifts have safety embedded in their DNA. Packed with tons of features that protect your health and your investment, these machines give you peace of mind in every task, every day.

▶ HILL START ASSIST

Hill Start Assist (HSA) ensures stability and prevents rollbacks by automatically activating the parking brake on slopes.



▶ ELECTRIC PARKING BRAKE (EPB)

The parking brake engages automatically to keep the vehicle stationary when the operator exits the seat.

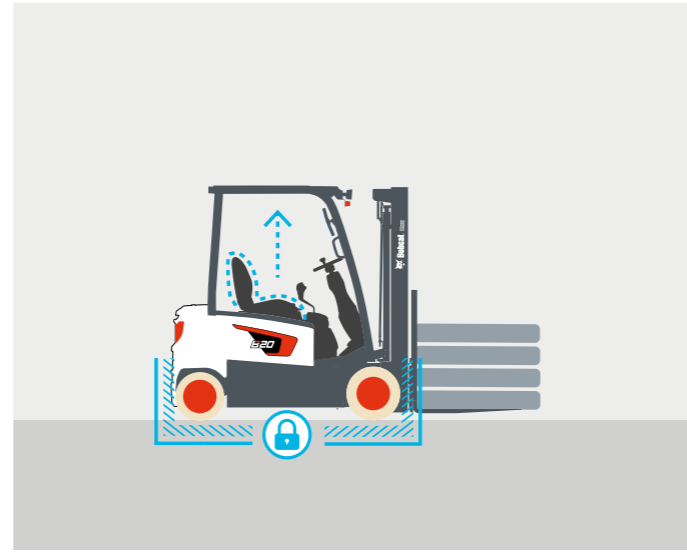

▶ ELECTRIC FOOT BRAKE SYSTEM (EFB)

Using advanced braking technology, the Electric Foot Brake system (EFB) springs into action when the operator eases off the accelerator for seamless control.

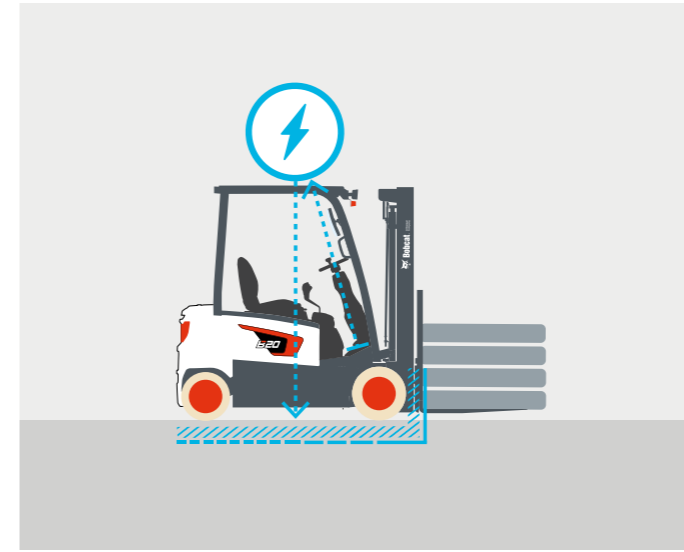

▶ MAST SWAY CONTROL

The updated design automatically reduces the vehicle's maximum speed by 50%, minimizes mast oscillation during operation at maximum height, and controls drive speed proportionally to the mast height. Plus, it includes the Guardian Stability System as standard.

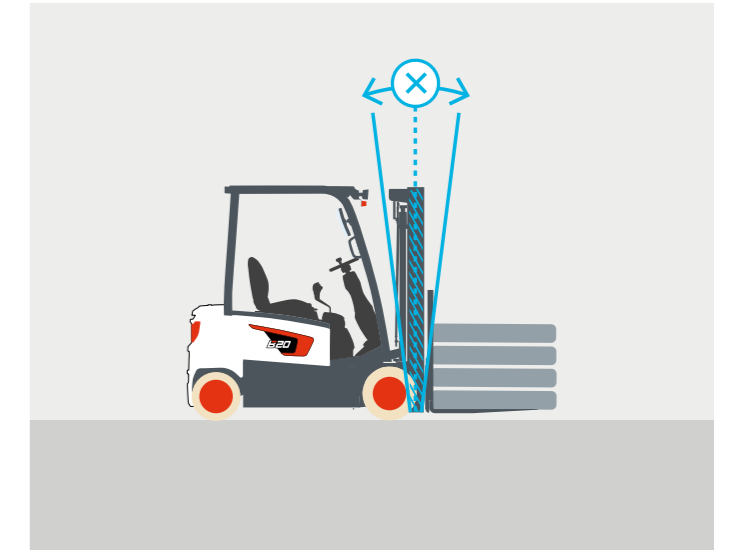

▶ MAST LOWERING INTERLOCK & TILT LOCK

The Mast Lowering Interlock & Tilt Lock system prevents unintentional lowering and tilting of the mast.

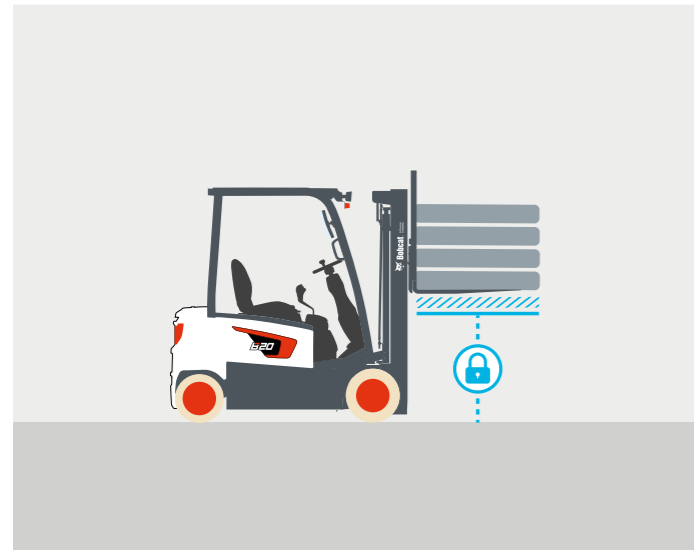

▶ DRIVE SPEED CONTROL

The drive speed control manages travel speeds, slowing the truck down when cornering to reduce the risk of accidents or damage.

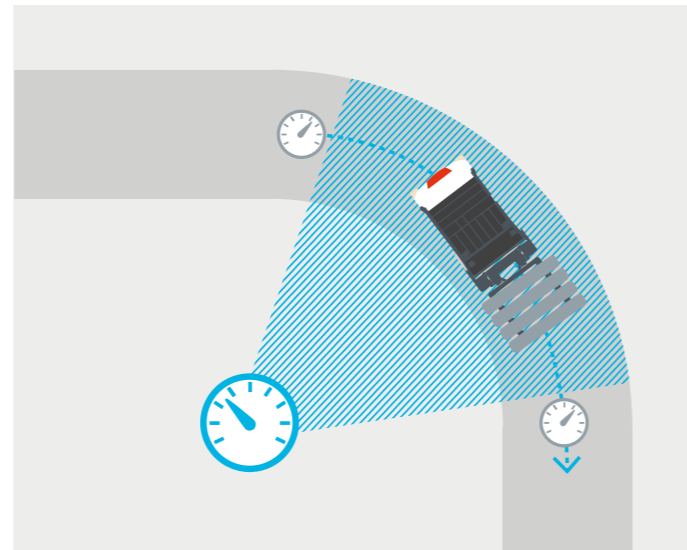

▶ LARGE PANORAMIC MIRROR

Providing great visibility of the rear working area, the large panoramic mirror improves safety and adds to overall productivity.



▶ RED FENCE LIGHTS

The vehicle projects red light-lines onto the ground, marking a safe area for pedestrians in close proximity to the vehicle.



Note: The illustrations show a 4-wheel truck with the same safety features as a 3-wheel truck.

BUILT TO LAST

▶ EXCELLENT RELIABILITY

Bobcat 7-Series Plus electric forklifts are built tough to provide maximum uptime and dependability thanks to a reliable AC controller, dust & water-resistant parts, and an additional drive motor cover.

THERE'S NO TIME FOR DOWNTIME. STAND UP TO EVERY TASK THAT COMES YOUR WAY, DAY AFTER DAY.



2 YEAR WARRANTY

▶ WARRANTY

Bobcat develops every machine to the highest standards of quality and durability. That's why our standard warranty provides 24 months or 2 000 operating hours (whichever occurs first) of coverage.



▶ PROTECTION PLUS EXTENDED WARRANTY

Enjoy total peace of mind with Protection Plus extended warranty. Providing the same level of protection as the standard warranty, Protection Plus also reflects different customer needs and expectations by offering a choice of durations and annual operating hours.

▶ EXTENSIVE DEALER NETWORK

You can rely on our network of dealers and service partners who are always ready to help you.

▶ BOBCAT GENUINE PARTS

Quality components delivered to our dealers ensure that our equipment is built to last, withstand the toughest conditions, and deliver reliable performance.

SPECIFICATIONS

TECHNICAL DATA ACCORDING TO VDI 2198										
		B15T-7 Plus	B18T-7 Plus	B20T-7 Plus	B16X-7 Plus	B18X-7 Plus	B20X-7 Plus	B25X-7 Plus	B30X-7 Plus	B35X-7 Plus
CLASSIFICATION		3-WHEEL ELECTRIC				4-WHEEL ELECTRIC				
Drive		AC electric								
Load capacity/rated load (kg)	Q	1500	1750	2000	1600	1800	2000	2500	3000	3500
Load center (mm)	c	500								
Load distance, center of drive axle to fork (mm)	x	376		381	376		381	448	454	
Wheelbase (mm)	y	1323	1423	1446	1495			1589	1734	1750
Service weight (with min. weight of battery) (kg)		3028	3142	3472	3189	3281	3461	4623	5068	5486
Tread front (mm)	b11	902		912	902		912		998	
Tread rear (mm)	b12	167		201	890				998	
Tilt of mast/fork carriage forward / backward (°)	α/β	5 / 7					6 / 9			
Height, mast lowered ¹ (mm)	h1	1 850 – 2 800					1 860 – 3 135		1 885 – 3 135	
Free lift ¹ (mm)	h2	135 – 2 060					147 – 2 240		147 – 1 940	152 – 1 760
Lift height ¹ (mm)	h3	2 700 – 7 020					2 950 – 8 250		2 950 – 6 010	2 720 – 5 655
Height, mast extended ¹ (mm)	h4	3 745 – 8 275		3 750 – 8 275	3 745 – 8 275		3 750 – 8 275	4 200 – 9 200	4 200 – 7 255	3 970 – 6 905
Height of overhead guard (mm)	h6	2 010					2 185		2 210	
Height of seat (mm)	h7	919							1 070	
Overall length (mm)	l1	2791	2891	2929	3020		3 025	3379	3530	3614
Length to forkface (mm)	l2	1891	1991	2029	2120		2125	2329	2480	2564
Overall width (mm)	b1/b2	1090		1119	1090		1119		1245	
Fork carriage width (mm)	b3	973					1 103		1 115	
Ground clearance loaded below mast (mm)	m1	86							130	
Ground clearance center of wheelbase (mm)	m2	100							140	
Aisle width for pallets 1000 × 1200 crossways (mm)	Ast	3216	3316	3354	3466		3471	3620	3772	3832
Aisle width for pallets 800 × 1200 lengthways (mm)	Ast	3341	3441	3479	3662		3667	3799	3950	4010
External turning radius (mm)	Wa	1515	1615	1648	1886			1950	2095	2155
Travel speed, loaded / unloaded (km/h)		17 / 17					16 / 18			
Lift speed, loaded / unloaded (mm/s)		400 / 600					480 / 600		420 / 600	380 / 600
Lowering speed, loaded / unloaded (mm/s)		500 / 450					490 / 460		500 / 460	
Max. drawbar pull, loaded (kg)		1 300								
Max. gradeability, loaded (%)		26	25	24	26	25	24	25 / 38	22 / 34	20 / 31
Battery voltage, nominal capacity K5 (V/Ah)		48 / 440		48 / 510		48 / 585		80 / 500		80 / 600

Specification values quoted in this specification sheet have been rounded. Performance may vary depending on operating conditions. Products and specifications are subject to improvement and change without prior notice.
¹ Mast dimensions refer to a range from the lowest to highest available with load backrest.

Note: Load capacities are based on the standard chassis without side shifter.

STANDARD EQUIPMENT & OPTIONS

STANDARD EQUIPMENT & OPTIONS	
SAFETY & STABILITY	
Easy entry grab bar	✓
Electro-magnetic automatic parking brake (EPB)	✓
Electric foot brake system (EFB)	✓
Mast sway & drive speed control	✓
LED lights	✓
Emergency stop switch	•
Auto tilt leveling	•
Fence light	•
Panoramic mirror	•
GUARDIAN STABILITY SYSTEM (GSS)	
OSS (Operator Sensing System)	✓
Neutral position for start	✓
Hill start assist	✓
Curve control speed	✓
Low battery warning alarm	✓
Seat belt indicator	✓
Mast lowering interlock & tilt lock (ISO 3691)	✓
Decrease of travel speed (up to 50%) when the mast is raised above the primary stage	✓
Forward tilt is reduced by 2° when the mast is raised above the primary stage	•
Alarm sounds when the mast is raised above the primary stage with the mast tilted more than 2°	•
PRODUCTIVITY	
Full AC system chassis	✓
Rounded design counterweight	✓
86° (BX) / 90° (BT) Steering angle	✓
Hydraulic cushioned valve in freelif cylinder (FFL & FFT)	✓
Battery lift/roll in and out system	•
Cooling options: Fans & Fin type controller	•

*This list is based on factory data. Standard or optional can vary for specific countries.

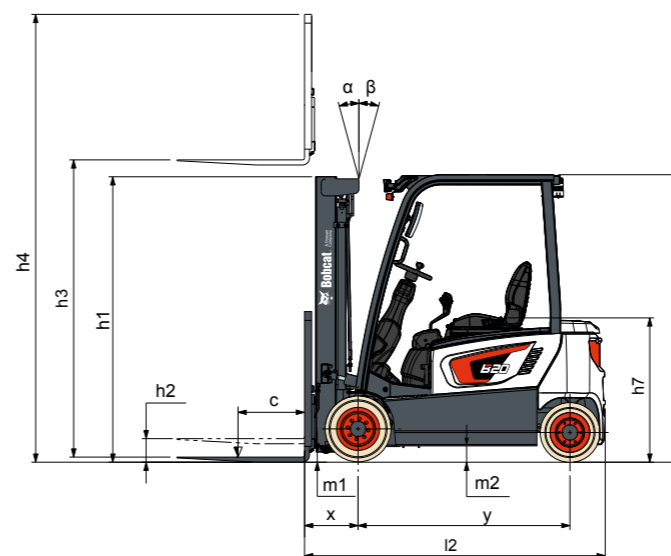

Note: The dimensional drawing is representative of both 4 and 3-wheel series.

STANDARD EQUIPMENT & OPTIONS	
ERGONOMICS	
Large entry step with anti-slip pattern	✓
Large & angled floor plate (leg room) with rubber cushion	✓
Rounded design battery hood cover	✓
Easy-to-read instrument panel	✓
Adjustable tilt steering column & easy grip steering wheel (Ø 280 size)	✓
Hydraulic control lever with direction switch	✓
Large cup holder, USB port & 12V port, clipboard	✓
Additional accessory bar	✓
Reduced noise level	✓
Fingertip controls	•
Rear grab bar with horn	•
Newly improved adjustable seats	•
Special height overhead guards	•
Mono pedal	•
Modular cabins	•
RELIABILITY	
Robust frame structure & overhead guard	✓
IP65 Rated Curtis controller	✓
IP43 Rated PAL enclosed type motors	✓
Improved cooling performance	✓
Controller cover	•
Belly plate	•
SERVICEABILITY	
Easy-to-access controller & motor room	✓
Wide open battery hood cover	✓
Durable heat-resistant cables (38"SQ)	✓
Tool-less side cover with air ventilation	✓
EasyView	✓

• = option
 ✓ = standard
 – = not available

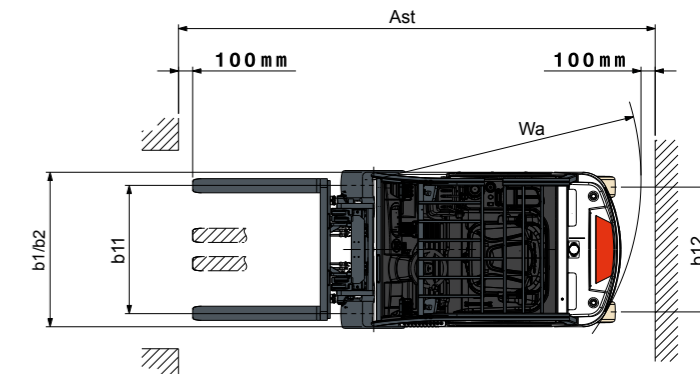

FINANCING OPTIONS

24, 36, OR 48 MONTH FINANCING*

Take advantage of 24, 36, or 48-month financing programs starting from 0% interest and improve your cash flow. Ask your dealer for the financing offers available.

340 MACHINES / 150 ATTACHMENT FAMILIES / 1 TOUGH ANIMAL



SKID-STEER
LOADERS



COMPACT TRACK
LOADERS

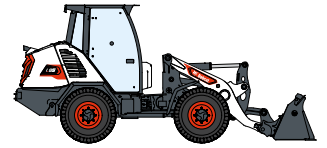

COMPACT WHEEL
LOADERS



FORKLIFTS

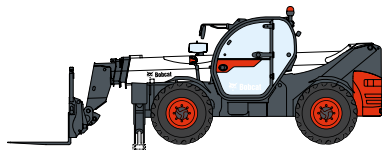

TELEHANDLERS

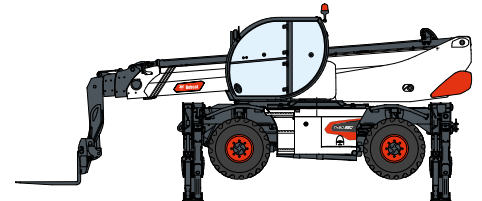

ROTARY TELEHANDLERS



LIGHT COMPACTION
EQUIPMENT

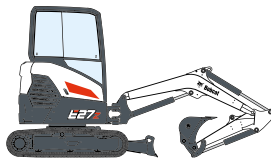

COMPACT
EXCAVATORS



COMPACT
TRACTORS

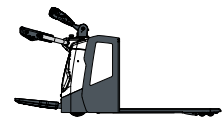

WAREHOUSE
EQUIPMENT



MINI TRACK
LOADER



MOWERS



PORTABLE
POWER

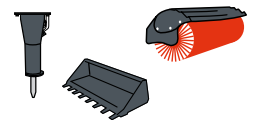

ATTACHMENTS

DOOSAN

Bobcat is a Doosan Company. Doosan is a global leader in construction equipment, power & water solutions, engines, and engineering proudly serving customers and communities for more than a century. | Bobcat and the Bobcat logo are registered trademarks of Bobcat Company in the United States and various other countries. ©2024 Bobcat Company. All Rights Reserved.



Bobcat®

*Financing options may vary by country and dealer. Always ask your dealer about currently available financing options. Terms and conditions may apply.

Doosan Bobcat EMEA, U Kodelky 1810, 263 12 Dobříš, Czech Republic